

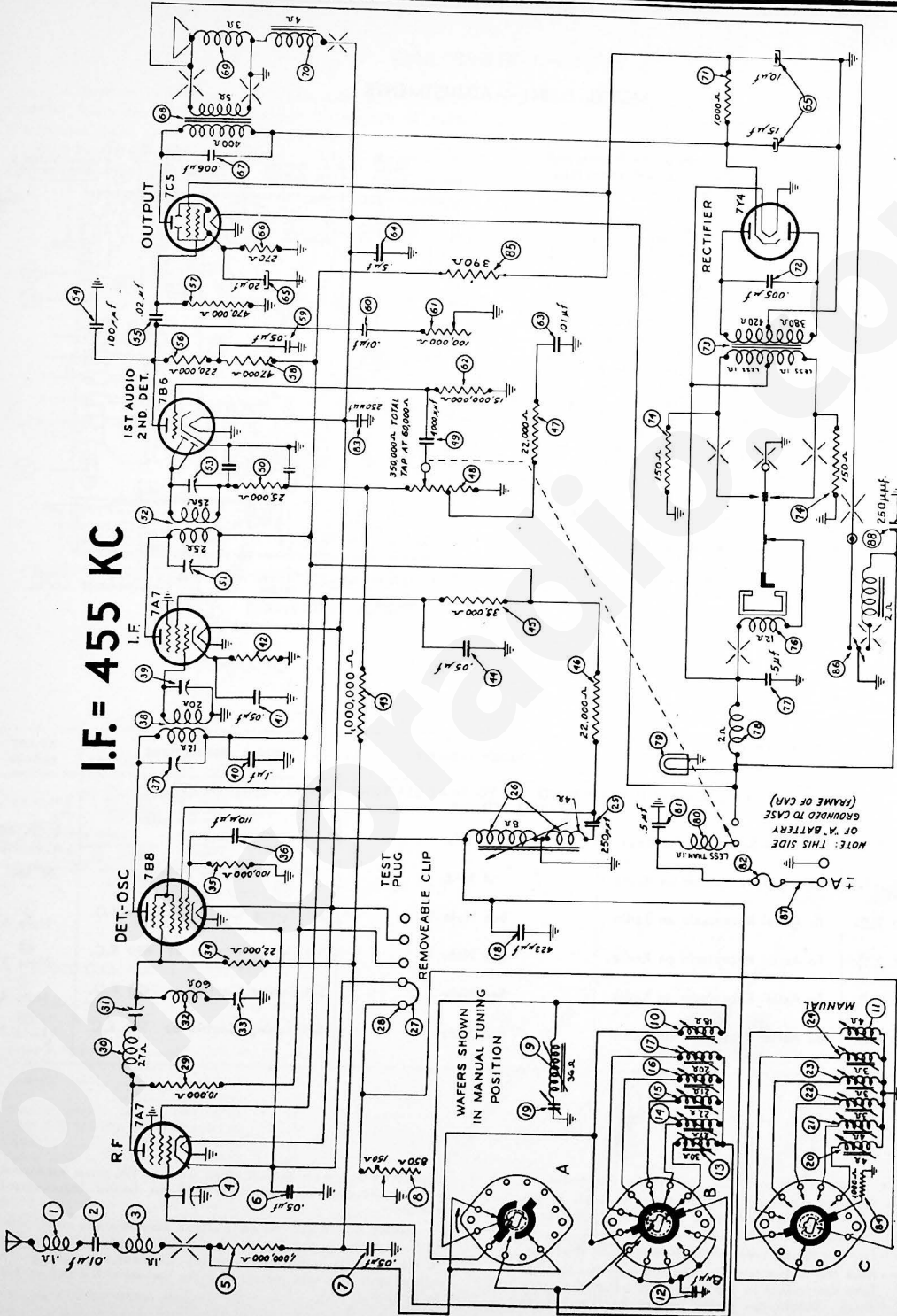

# MODEL F-1841 FORD CUSTOM AUTO RADIO (CONTINUED)



# MODEL F-1841 FORD CUSTOM AUTO RADIO (CONTINUED)

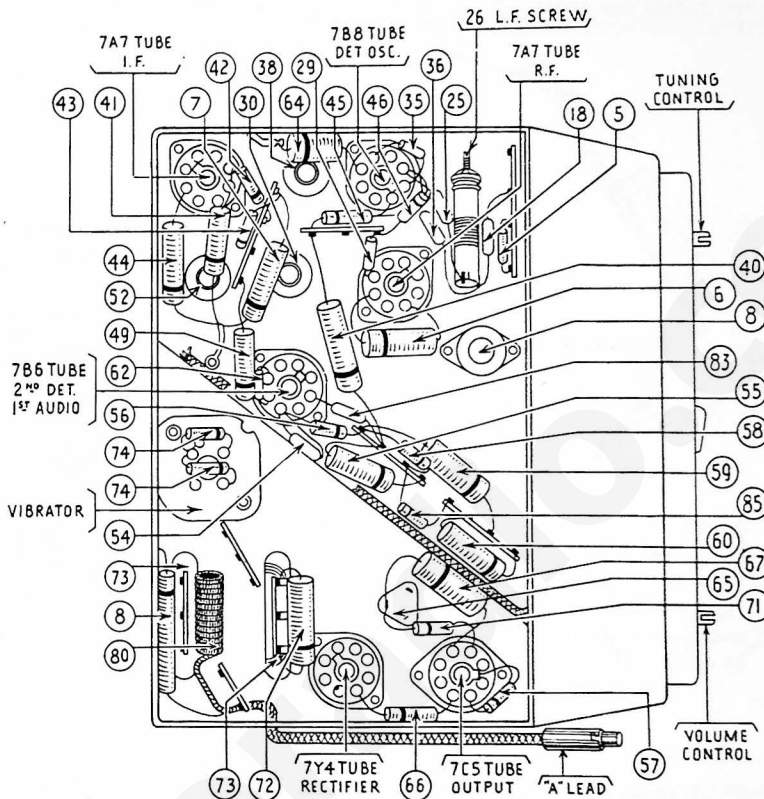

FIGURE 3

## PARTS LIST — F-1841

No.	Description	Part No.	No.	Description	Part No.	No.	Description	Part No.
1	Antenna Choke	65-0102	29	R. F. Transformer (Sec.) Part of 28	61-0110	71	Speed Nut (Dial Mtg.)	97-0136
2	Condenser (.01 Mfd.)	61-0114	30	Padder (Part of 28)	61-0106	72	Dial	55-1143
3	Antenna Choke	32-2063	31	Resistor (22,000 ohms)	33-322334	73	Bezel	55-1140
4	Aerial Compensator	63-0063	32	Resistor (100,000 ohms)	33-410154	74	Bezel Spring	57-1769FA3
5	Resistor (1,000,000 ohms)	33-510154	33	Condenser (10 Mmfd.)	61-110157	75	Bezel Clip	57-1723FA3
6	Condenser (.05 Mfd.)	61-0111	34	Padder (Pri. 1st I. F. Trans.)	65-0387	76	Tone Knob	57-1780FA3
7	Condenser (.05 Mfd.)	61-0101	35	First I. F. Transformer	65-0386	77	Tone Knob Speed Nut	97-0144FE7
8	Image Trap Coil	Part of 6	36	Padder (Sec. 1st I. F. Trans.)	61-0113	78	Tone Slide Bar	57-1744FA3
9	Sensitivity Control	67-0025	37	Condenser (.1 Mfd.)	61-0113	79	Tone Knob Spring	57-1937
10	Inductive Tuning Unit	77-0701	38	Condenser (.05 Mfd.)	61-0101	80	Drive Cord	55-1137
11	Oscillator Transformer	Part of 6	39	Resistor (10,000 ohms)	33-210334	81	Drive Cord Spring	57-1425FA3
12	Condenser (8 Mmfd.)	60-008337	40	Resistor (1,000 ohms)	33-210334	82	Pointer	57-1794FCP
13	Push Button Transformer	Part of 10	41	Condenser (1,000,000 ohms)	33-510154	83	Screw	(Wiring Side Cover) W2212FA4
14	Assembly	77-0815	42	Condenser (.05 Mfd.)	61-0101	84	Housing	318-2411
15	Push Button Transformer	Part of 13	43	Resistor (33,000 ohms)	33-333434	85	Wiring Side Cover	57-1718FC1
16	Push Button Transformer	Part of 13	44	Resistor (22,000 ohms)	33-322334	86	Speaker Cover	57-1717FC1
17	Push Button Transformer	Part of 13	45	Resistor (22,000 ohms)	33-322154	87	Speaker Unit	73-0054
18	Push Button Transformer	Part of 13	46	Volume Control (350,000 ohms) & On-Off Switch	67-0042	88	Bolt (Speaker Mtg.)	W1582FA4
19	Silver Mica Condenser (423 Mmfd.)	61-0066	47	Condenser (4,000 Mmfd.)	61-0129	89	Lockwasher (Speaker Mtg.)	W291FE7
20	Image Trap Padder	63-0071	48	Resistor (25,000 ohms)	33-325154	90	Nut (Speaker Mtg.)	W124FA3
21	Push Button Transformer	Part of 13	49	Padder (Pri. 2nd I. F. Trans.)	65-0387	91	Loktil Socket	27-6151
22	Push Button Transformer	Part of 13	50	Second I. F. Transformer	65-0387	92	Vibrator Socket	27-6153
23	Push Button Transformer	Part of 13	51	Padder (Sec. 2nd I. F. Trans.)	61-01157	93	Wafer Switch	77-0817
24	Push Button Transformer	Part of 13	52	Condenser (100 Mmfd.)	60-110157	94	Hook Bolt (Radio Mtg.)	97-0094FA3
25	Push Button Transformer	Part of 13	53	Condenser (.02 Mfd.)	61-0108	95	Wing Nut (Radio Mtg.)	97-0048FA3
26	Push Button Transformer	Part of 13	54	Resistor (230,000 ohms)	33-422334	96	Gland Nut & Sleeve	77-0459
27	Condenser (250 Mmfd.)	60-129157	55	Resistor (470,000 ohms)	33-447154	97	Interference Condenser ("A" & Voltage Regulator)	61-0162
28	Oscillator Tracking Transformer	65-0388	56	Resistor (47,000 ohms)	33-347334	98	Interference Condenser (Oil Gauge & Dist.)	61-0163
29	Test Link	65-1121	57	Condenser (.05 Mfd.)	61-0122	99	Ground Lead Assembly (Voltage Regulator)	77-0810
30	Test Socket	55-1104	58	Condenser (.01 Mfd.)	61-0176			
31	Resistor (10,000 ohms)	33-310334	59	Tone Control (100,000 ohms)	85-0128			
32	R. F. Transformer (Pri.)	65-0415	60	Resistor (15,000,000 ohms)	33-615154			
33	Padder	Part of 4						
34	Condenser (.01 Mfd.)	61-0110						
35	Condenser (.5 Mfd.)	61-0106						
36	Filter Condenser (10-15-20 Mfd.)	61-0089						
37	Resistor (250 ohms)	33-127436						
38	Condenser (6,000 Mmfd.)	61-0105						
39	Output Transformer	65-0391						
40	Replacement Cone (For 73-0054-3 Speaker)	91-0210						
41	(For 73-0034-9 Speaker)	91-0211						
42	Field Coil	Not Replaceable						
43	Resistor (1,000 ohms)	33-210334						
44	Condenser (5,000 Mmfd.)	61-0153						
45	Power Transformer	65-0347-N						
46	Resistor (150 ohms)	33-115334						
47	Vibrator	83-0026						
48	Condenser (.5 Mfd.)	61-0137						
49	Vibrator Choke	65-0398						
50	Pilot Lamp	31-2084						
51	"A" Choke	65-0087						
52	Condenser (.5 Mfd.)	61-0137						
53	Fuse	45-2859						
54	Condenser (250 Mmfd.)	60-125157						
55	Resistor (1,000 ohms)	33-210334						
56	Resistor (390 ohms)	33-139334						
57	Foot Switch Control	77-0808						
58	Fuse Lead Assy.	77-0834						
59	Condenser (250 Mmfd.)	60-125157						
60	Siliconoid	65-0422						
61	Siliconoid Core	57-2069						
62	Selector Switch Knob							
63	Assembly	318-2376						
64	Tuning & Volume Knob	77-0708						
65	Rubber Baffle Gasket	55-1154						
66	Speaker Cover Screw	W2212FA4						

# MODEL F-1841 FORD CUSTOM AUTO RADIO (CONTINUED)

1941 CLOSED CAR AERIAL

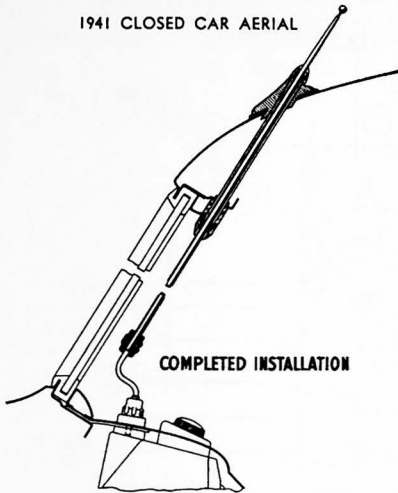

COMPLETED INSTALLATION

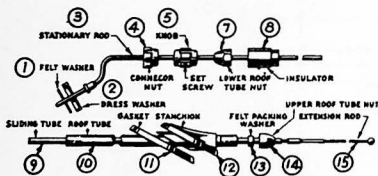

FIGURE 4

CLOSED CAR AERIAL PARTS LIST (Figure 4)

No.	Description	Part No.	List Price
①	Felt Washer (per 100)	55-0811	\$1.25
②	Dress Washer	57-1137FA8	.10
③	Stationary Tube	77-0728	.90
④	Connector Nut	55-1166	.15
⑤	Knob	77-0723	.40
⑥	Knob Set Screw	W2105FA4	.10
⑦	Lower Roof Tube Nut	57-1131FA8	.15
⑧	Insulator	55-0783	.10
⑨	Sliding Tube	77-0725	.85
⑩	Roof Tube	77-0724	.50
⑪	Gasket	55-0785	.05
⑫	Stanchion	55-0781	.15
⑬	Felt Washer	55-0786	.02
⑭	Upper Roof Tube Nut	57-1135-FA8	.15
⑮	Part of ⑥		
	Set Screw Wrench	28-4696	.10
	Template	57-1828	.05
	Complete Aerial	91-0178	3.50

Prices subject to change without notice.

OPEN CAR AERIAL PARTS LIST (Figure 5)

No.	Description	Part No.	List Price
①	Aerial Rod	77-0866	\$1.25
②	Gasket	55-0285	.03
③	Adjusting Screw	57-1836	.06
④	Aerial Head & Shaft Assy.	91-0182	2.75
⑤	Aerial Insulator Assy.	55-1165	.45
⑥	Insulating Bushing	55-1300	.40
⑦	Control Knob	77-0736	.50
⑧	Rubber Grommet	77-0735	.25
⑨	Lead-in Tip	57-1838	.40
⑩	Lead-in Rod	77-0734	.45
⑪	Connector Nut	55-1166	.15
⑫	Dress Washer	57-1137	.10
	Lead-in Spring (per 100)	55-0811	1.25
	Set Screw Wrench	28-4696	.10
	Screw (Aerial Rod)	W1944	.10
	Complete Aerial	91-0179	4.50

Prices subject to change without notice.

1941 OPEN CAR AERIAL

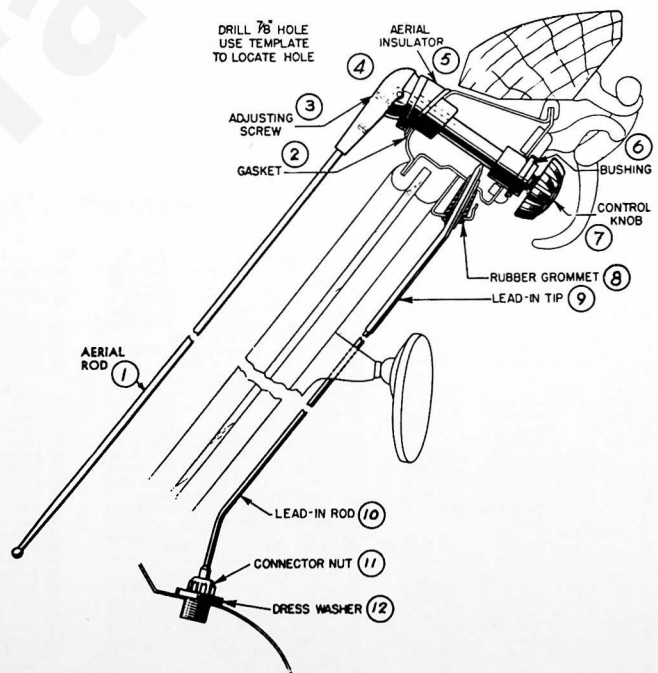

FIGURE 5